

Spec-Tech Industrial Electric
203 Vest Avenue
Valley Park, MO 63088
(P) 636/537-0202 (F) 636/537-1405
sales@spectechind.com

OnGuard Continuous Level Monitor

Installation

- 1) Mount OnGuard Panel in area near the tank.
- 2) Bring 120VAC Power to panel and make connections (L1, Neutral & Ground).
- 3) Connect the sensor(s) to the appropriate terminals on the power strip. Follow the connection diagram included with the OnGuard panel. An example is shown below.

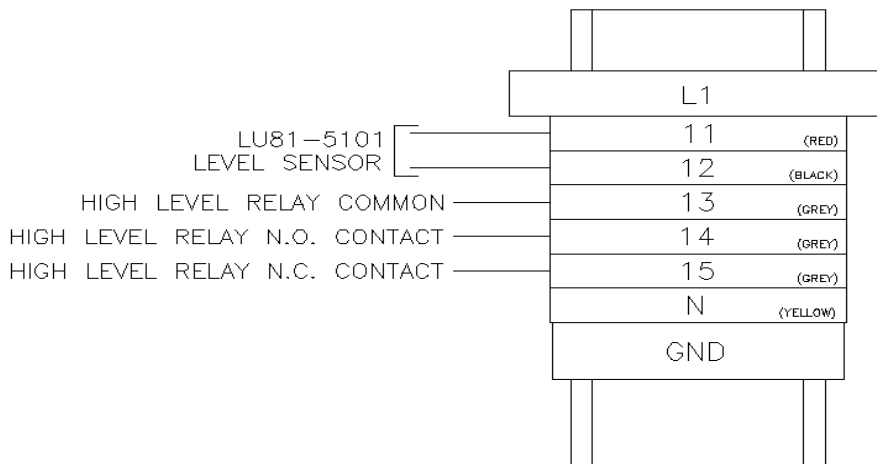

- 4) Mounting of the Ultrasonic sensor:
 - a. Do not install at angle relative to the liquid. Sensor should be perpendicular to the liquid.
 - b. Do not install within 3" of the tank sidewall
 - c. Do not install with objects in the beam, i.e. ladders, agitators, baffles, etc.
 - d. Do not install in applications with a vacuum
- 5) Verify that all connections are made correctly & secure. Turn the power on to the panel.